



Factron
A BETTER SOLUTION

QHC03MR 3kW Heater Controller (Receiver)



Single Phase 240v / Single Channel / Soft Start

Remote Operation

Quick Start for QHC03MR 3kW Heater Controller (receiver)

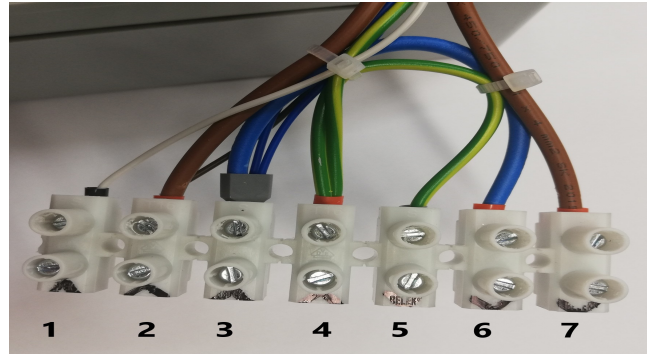
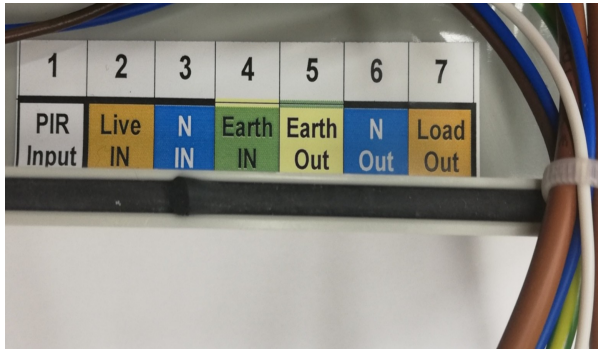

- 1) Remember isolate the Mains before removing the cover. Remove the cover by removing the 4 screws. There is a terminal strip connector for connecting the Mains IN and Mains OUT.
- 2) Use the three cable glands to bring the Mains cables into and out of the controller base .
- 3) Connect Mains IN - Live brown (2), Neutral blue (3) and Earth green/yellow (4) wires to terminals marked Live IN (2), N IN (3) and Earth IN (4).
- 4) Connect the Infrared Heater - the brown Live wire to Load Out (7), the blue Neutral wire to N Out (6) and the green/yellow Earth wire to Earth Out (5).
- 5) The trigger from a motion detector (PIR) QHPIR is connected to terminal PIR Input (1).
- 6) When all connections are complete and connected correctly, check once again that the wiring is correct as per 3) & 4). Then replace the cover and tighten the fixing screws.
- 7) Turn ON or reconnect the Main Power to the controller. The red neon lamp on the LHS will illuminate to indicate that the unit is **LIVE**.
The controller is now ready to be controlled by the wireless remote unit **QHVCR**. See instructions for QHVCR operation, page 2 follow steps 8) to 14).

**Important only a qualified electrician can install this device.
Remember to fit Type C MCB circuit breakers & a fused spur for each heater.**

QHVC R 3 Zone Remote Master Controller (transmitter)

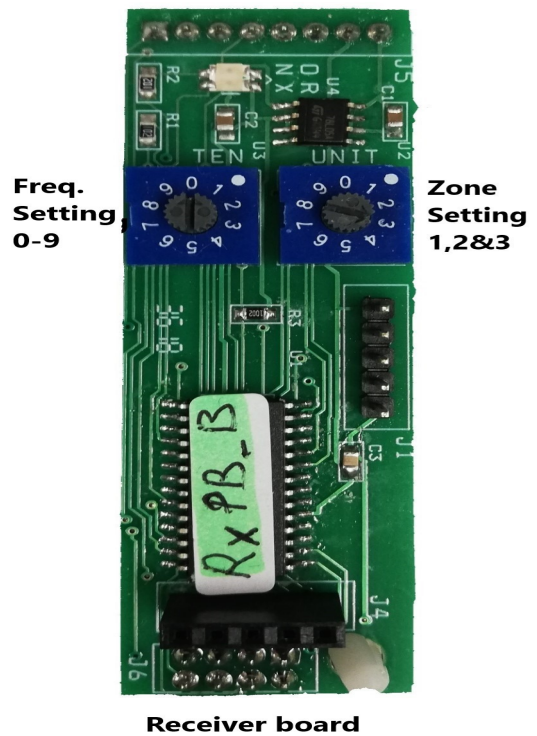

- 8) There are three control dials Blue, Yellow & Red one for each zone. The QHC03MR units are preset to operate in one of these zones. The QHC03MR unit once preset will only operate in that designated zone. The factory setting is 1, this will be the Blue control dial.
- 9) Turn ON the QHVCR unit by pressing the ON/Standby button on the front panel. The Led indicator will flash orange – green – orange – green and remain Green to indicate that the unit is ready.
- 10) The QHC03MR unit is preset as a Blue zone (1). Turn the Blue control dial to position **1**. The heaters connected to the QHC03MR units will come ON at the minimum setting 33%. Continue to turn the Blue control dial through position 2 to 4 until you reach the desired setting. Settings are **OFF** = 0%, **1** = 33%, **2** = 50%, **3** = 66% & **4** = 100%.
- 11) QHC03MR units which are preset to Yellow & Red zones are controlled by the Yellow & Red control dials respectively and will operate as above in 10).
- 12) The QHVCR unit is powered by 3 x AAA battery's. So, the unit will automatically go into standby mode if the unit is inactive for more than 30 seconds. When the unit goes into standby mode all the QHC06MR units will remain unchanged at the settings they were set at. The heaters will remain ON.
- 13) To change a setting just press the ON/Standby button and proceed as described in 9) & 10). However, while the QHVCR unit is ON, you can turn OFF all the heaters by pressing the ON/Standby button. This is indicated by the Led indicator flashing Red.
- 14) The previous settings will be remembered and will be restored when you press the ON/Stand by button again.
Please note that the QHVCR remote Master Controller can control any number of QHC03MR & QHC06MR controllers as long as they are within range, up to 100 meters * (see specification sheet for the QHVCR unit)

Pairing (programming) Devices QHVCr & QHCxxMR

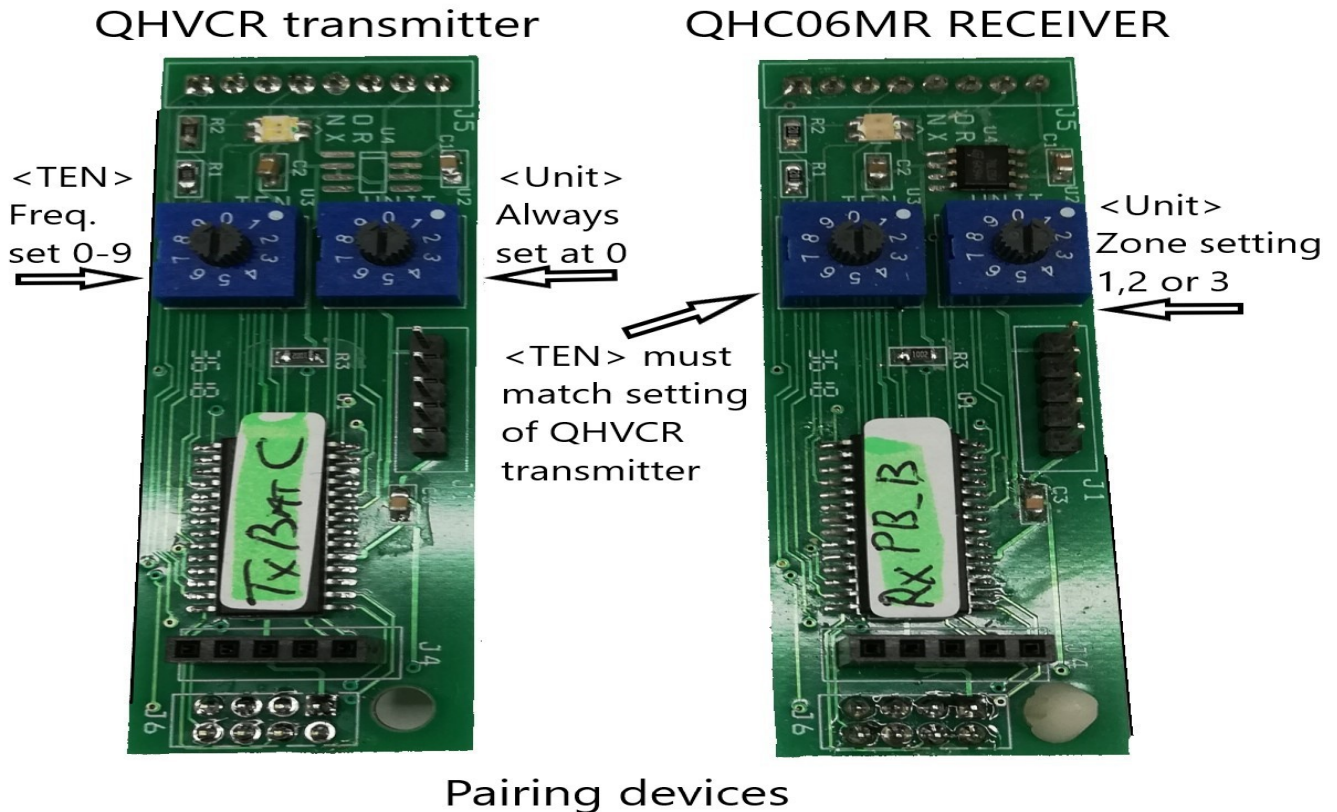

Pairing (programming) devices QHVCR (transmitter) and QHCxxMR (receivers).

- 1) The Left Hand Side rotary switches (TEN) on both boards must be set the same. The LHS switch (TEN) is used to set the RF frequency the setting must match on both boards. There are **10** possible frequencies that can be selected **0-9**. If the settings on the LHS switch (TEN) do not match the devices will fail to operate.

Designating the transmitter and receiver. Both the left rotary switches are set at **0**, this ensures that the transmitter marked **0** will communicate with the receiver marked **0**. Setting the left rotary switch to **1**, so the transmitter marked **1** will communicate with a receiver also marked **1**.

If the transmitter and receiver are not paired correctly they will not communicate and therefore will not operate; transmitter marked **0** will **not communicate** with a receiver marked **1**.

Remember a transmitter can be set at any number between **0-9** & the receiver must be matched correctly.

- 2) The Right Hand Side rotary switches (UNIT) are for setting the device to operate in a set zone. There are 3 possible zones that the controller can be set to. The RHS switch (UNIT) should be set to 1,2 or 3.

Blue Zone 1 operation set RHS switch (UNIT) to **1**

Yellow Zone 2 operation set RHS switch (UNIT) to **2**

Red Zone 3 operation set RHS switch (UNIT) to **3**

PIR motion detector (QHPIR) fitting

PIR motion detector
230v operation
QHPIR



PIR motion detectors are passive infrared sensors an electronic device which is triggered by infrared light from the movement of objects in it's field of view. A PIR can be connected to a QHC03MR controller.

This will enable the controller to turn ON the heaters only when the presence of a person or people are detected by the PIR.

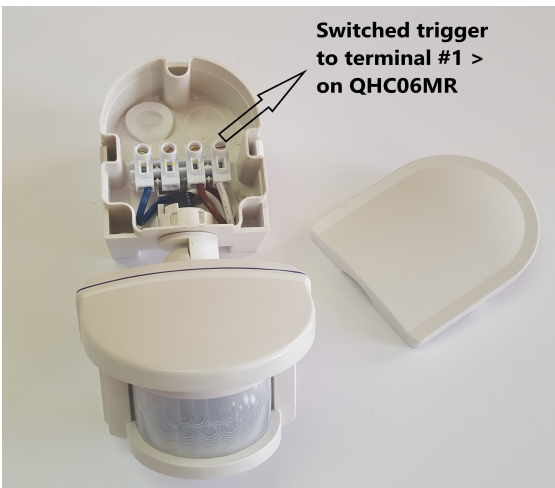

The angle of the PIR and the viewing width of the lens will have to be adjusted to ensure the detection area is that which is required. Full lens width will have a large detection area. For a smaller area the lens narrow the lens using the lens mask.

Setting the Lens width correctly is crucial, if this is set incorrectly the PIR could be continuously be ON. This can cause the heaters to remain ON too.

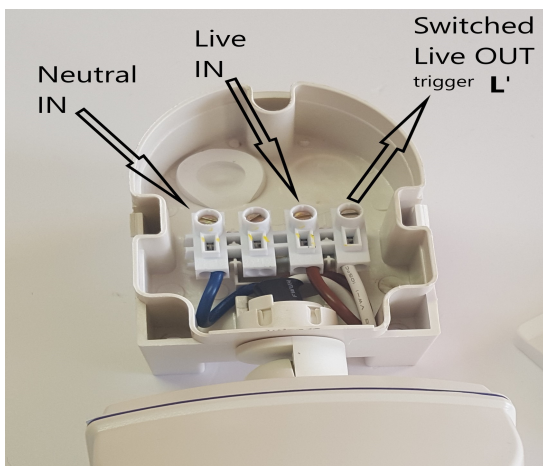

Connect the switched trigger to terminal #1 PIR Input on the QHC03MR controller.

The switched Live OUT to the QHC03MR controller is a Live 240V feed, this is only used as a signal Input to the controller.

7-Day programmable timer fitting option

A 7-Day programmable timer can be fitted as an option instead of the PIR. It is important to note that only one or the other can be fitted to the QHC03M controller **not both**.

S1 & S2 are found on the printed circuit board (PCB) QHPCB-A, See fig 12

Default settings for S1 & S2

Remote **OFF** – **S1** Jumper is factory set in the Off position pins 2 & 3,. For Manual operation.
 PIR & 7-Day Timer **OFF** - **S2** Slide switch is factory set in the Off position “ 2”. See Fig 12

To set up for a 7-Day programmable timer

S2 Slide switch must be set in the ON position “1”, See Fig 12

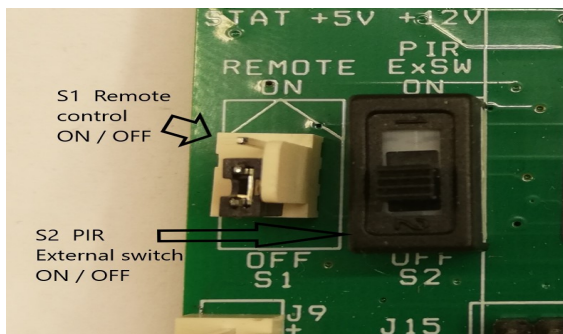

Fig 12 Slide switch S2 OFF position

Fig 13 Typical 7-Day Programmable Timer

Wiring Diagram - neoStat to QHC06M Controller

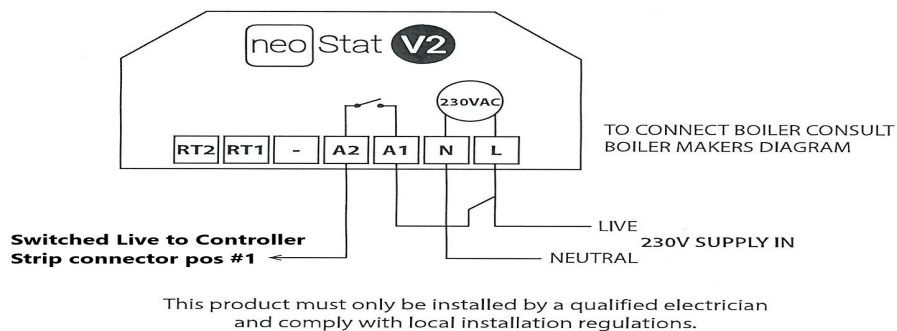

Fig 14 Wiring connection to the QHC03M controller

The switched Live through A2 terminal on the 7-Day timer is connected to position 1 on the strip connector of the QHC06M controller See Fig 1,2 & 14.

Once the 7-Day programmable timer is fitted correctly it will now control when the controller will be ON or OFF.

This function can be disabled by simply switching the S2 slide switch back to the OFF position 2 See Fig 12

Expandable heating system using a QHVCR & multiple QHC03MR, QHC06MR & QHC18MR controllers.

Using the remote 3 zone QHVCR controller the area being heated can be zoned into three area's Blue, Yellow & Red. Each zone can be controlled separately, this includes setting each zone at a different level. There are 5 setting levels > Off - 1 (33%) - 2 (50%) - 3 (66%) - 4 (100%).

Any combination of our QHC controllers can be used in the proposed zoned layout below. There are 3kW QHC03MR, 6kW QHC06MR & 18kW QHC18MR controllers available to be used depending on the over all number of heaters required.

 Blue zone 6kW controller set a (0) > 0-1



Blue zone has 3 x 2kW heaters Total 6Kw

 Yellow zone 6kW controller set as (0) > 0-2



Yellow zone has 1 x 6kW heater Total 6kW

 Red zone 18kW controller set as (0) > 0-3

Red zone has 1 x 12kW heater Total 12kW



Remote 3 zone QHVCR controller set as an (0) > 0



This configuration allows the heaters in the Blue zone be controlled by the 1st dial on the remote control, setting levels at Off to 4. The Yellow zone is controlled by the 2nd dial & the Red zone is controlled by the 3rd dial.

For larger installations multiple controllers and heaters can be added to each zone where required.

It is recommended that each heater should be fused with a spur. Each controller should have a Type C MCB circuit breaker and the whole installation must have an Isolation switch.

Troubling shooting

- 1) The QHC06MR (receiver) is not working.

Check that the unit is wired correctly and follow the installation procedure on page 1. The neon indicator should be ON to indicate the the Mains is connected correctly.

Then check that the status LED D5, the +5v LED D6 & the +12v LED D7 are all ON green. If the status LED is Red, this indicates that there is a problem with the mains connection to the board.

If the +5v or +12v LEDs are Red this indicates that there is a problem with the processor chip or a power supply problem.

- 2) There is no communication between the QHC03MR & QHVCR

The units may not be paired correctly. First determine what frequency the QHVCR is set at. The setting is marked at the back of the unit. If it's marked **(0)** you must check to see if the QHC06MR is also set the same and is also marked **(0)**. If they are different then the controller QHC06MR will not work.

If needed you can reset the controller QHC03MR by following the Pairing instructions on page 3.

- 3) Paired transmitter QHVCR & receiver QHC03MR still won't communicate even when they are both set the same. The small antenna RF PCB could be the problem. Check if the small LED flashes Red when the transmitter QHVCR is turn ON & OFF. The communication is good between the two units when the LED flashes Red. Otherwise if the LED remains ON Green then the RF PCB is faulty and needs to be replaced.

However, if the RF PCB is working and the LED flashes Red but the controller QHC03MR is still not working. The cable connection between the RF PCB and the Antenna could be faulty and may need to be replaced.

- 4) Yellow zone is not working !

The problem could be the receiver is set as a blue zone or red zone. If this is the case all you have to do is re-set the right hand rotary switch to position 2. See page 3

- 5) Circuit Breaker MCB keeps tripping when the heaters are turned ON !
Ensure that the MCB is a Type C where there are likely to be surges. A common fault is to use Type B but these will always fail. Replace with Type C and the problem should be fixed.

- 6) If the controller does not respond to settings 3 & 4.

Check the for a loose or missing Black connector ref. J8 (TMP2) header on the printed circuit board (PCB).

Wiring diagrams

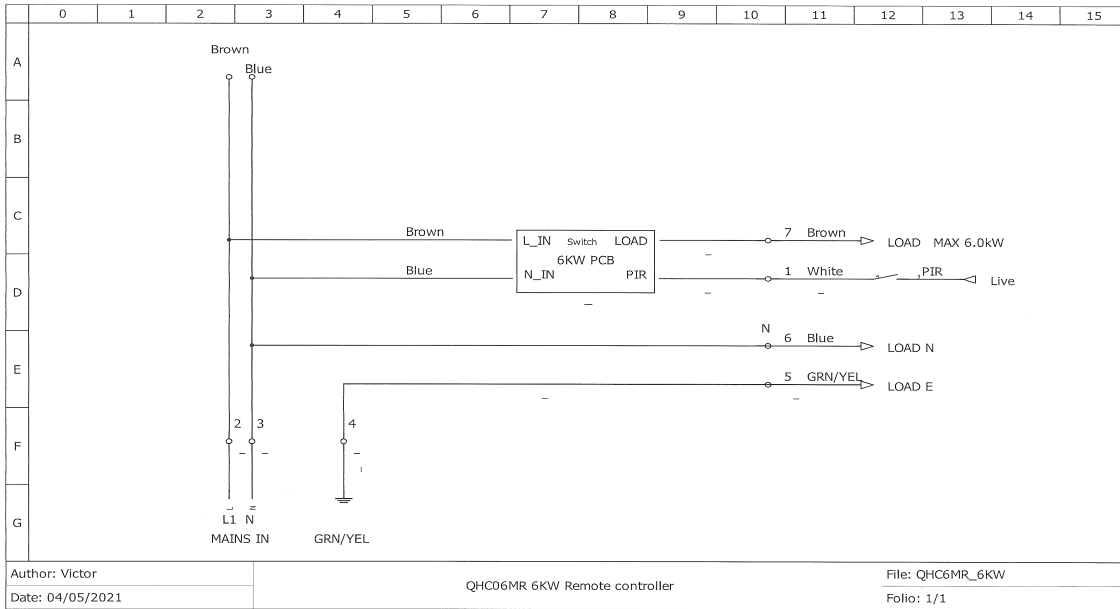

Wiring diagram for 3kW & 6kW controllers.

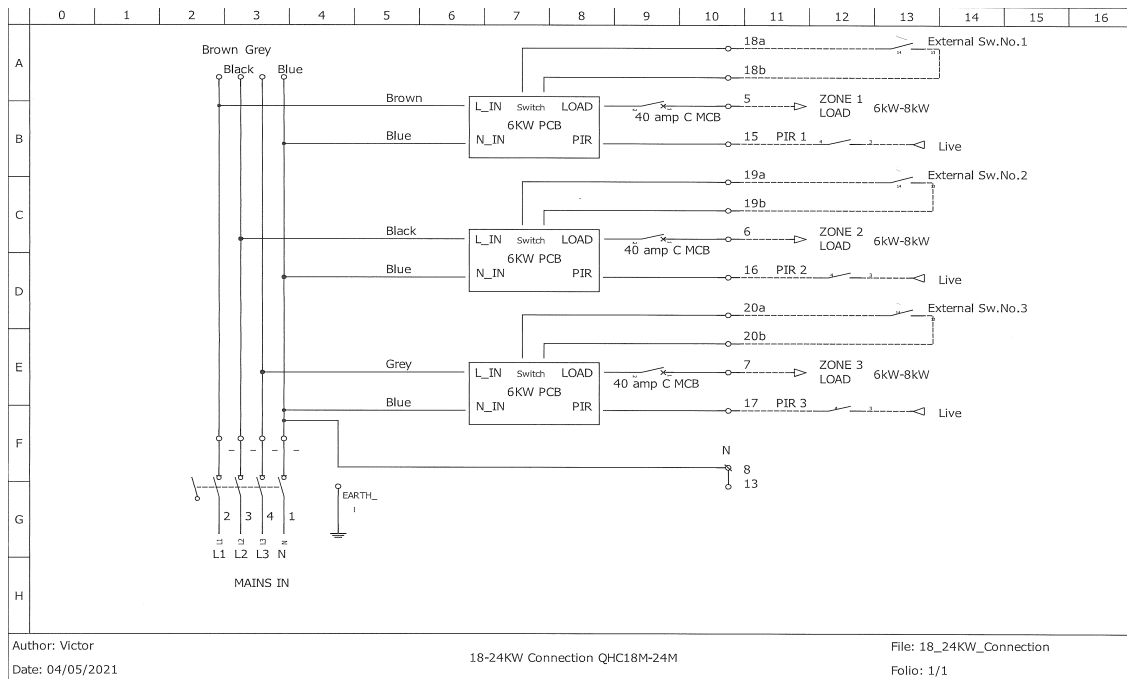

Wiring diagram for 18kW & 24kW controllers.

**Important only a qualified electrician can install this device.
Remember to fit Type C MCB circuit breakers & a fused spur for each heater.**

Supply voltage : Single phase 240v AC 50 Hz

Max. Load capacity : 3 kilo Watt

Input :	Live (Brown)	terminal #2
	Neutral (Blue)	terminal #3
	Earth in (Grn/Yel)	terminal #4

Input :	PIR input trigger	terminal #1
----------------	--------------------------	--------------------

Output :	Switched Live out (Brown)	terminal #7
Soft start	Neutral return out (Blue)	terminal #6
	Earth out (Grn/Yel)	terminal #5

Transmission: RF 433mHz

Range : Antenna	100 meters *(Line of sight)
Extended	200 meters *(Line of sight)

IP Rating: IP56

Dimensions : 150mm x 120mm x 90mm

Weight : 1 Kg

**Notes: Type C MCB circuit breakers must be used when installing this product.
It is recommended that heaters connected to this controller should be fused
individually with a fused Spur.**



Factron
A BETTER SOLUTION

Tel. 00 353 1 8352718 Email: dave@factron.ie

Website: www.factron.ie